



Product Innovations

Laboratory End-Fittings and Eye Showers

Hygiene and Safety

SAFETY
MADE IN
GERMANY

 NOVALAB

Content

Safety for guaranteed clean drinking water	6
Hygienic Flushing Modules	8
End-Fittings	10
Antibacterial Grips	22
Eye Showers	24

NOVALAB
Labor- und Gartenarmaturen GmbH
Brunsbütteler Damm 440
13591 Berlin, Germany

Phone: +49 30 364033620
E-Mail: info@novalab-gmbh.de
www.novalab-gmbh.de



Hygiene Flushing Systems and End-Fittings for Water



Safety for guaranteed clean drinking water

By the time drinking water has reached the end-fitting it has been subject to a variety of influences. The end-fittings from NOVALAB guarantee the flow of hygienically pure water.

Drinking water is the most important type of water and therefore subject to extremely strict regulations and controls. Drinking water is generally defined as a water for human usage such as for instance: drinking, preparing of food as well as personal hygiene and care.

Qualitative hygienic safety in all areas

A strict and sophisticated measuring and analysis system ensures that the public water supply system (waterworks) is only fed with water of drinking water quality. This quality must not be contaminated on its way to the consumer.

However, there is always the possibility that by the time the water has flowed through the house installation system it will have been subject to pollution with isolated pathogenic germs which are under an illness-causing concentration. Unfavourable hydraulic conditions can encourage a gradual multiplication of these germs which can then become potentially infectious.

Not only can a favourable temperature encourage the growth of germs but also stagnation somewhere along the installation system which can, in particular, contribute to a hygienic hazardous situation. A conspicuous cause of such stagnation can be unused, rarely used or only sporadically used end-fittings at the end of the installation system.

A timely detection of such dangers can be ensured through regular microbiological examinations of public or commercial installation systems under the responsibility of owners or operators. Should a microbial contamination with pathogens be detected, an immediate and effective decontamination of the system must be ensured. This involves high costs for material, personnel and time which can be minimized through taking preventive measures.



Hygienic safety in laboratories

Installation systems which are hydraulically connected to a drinking water supply system must carry water in drinking water quality in accordance with the Drinking Water Ordinance to all end-fittings. This is also applicable for laboratory installations. However, because drawing points in laboratories are subject to rare or sporadic use, the danger of stagnation is especially high and consequently the risk of microbial contamination. This endangers not only the user but also the entire connected hydraulic installation system.

Therefore, in order to effectively avoid such a situation, it is extremely important to flush either selected system-parts or the complete system at regular intervals. This solution has been proven as very effective and can be achieved by using personnel, time consuming and error-prone manual intervention. The optimal solution, however, is the "automated flushing system" from NOVALAB.



Autonomous flushing system for all demands

Although the autonomous flushing system from NOVALAB has been developed especially for laboratory installation systems it is also compatible with any other water supply system. The flushing intervals and flushing durations are freely programmable and functional for both cold and hot water supplies.

The NOVALAB hygienic flushing module is equipped with an integrated solenoid valve and programmable electronic controls. Therefore, the water system can be flushed at set intervals and set durations regardless of the usage of the system.

The water system can also be flushed by means of "intelligent" end-fittings. These fittings at the end of the system can flush the system automatically according to flushing intervals programmed.

The NOVALAB electronic end-fittings for non-contact utilization are equipped with an integrated use-related hygienic flushing system which triggers off an automatic flushing process.

The flushing intervals and flushing durations can be individually programmed according to demands. The power is connected by means of plug-in power or for mains-independent solutions via battery and therefore qualify for retrofit solutions.

From an economic perspective, these electronic flushing systems are exceptionally beneficial, especially for end-fittings which are rarely or very seldomly used but still must meet the highest standards of safety and hygiene.

Additionally, NOVALAB electronic end-fittings reduce water and energy consumption due to the utilisation only when needed. The non-contact operation of these end-fittings prevents pathogenic germs being transferred from one user to another.

NOVALAB hygienic flushing module

for cyclical flushing of water pipes
that are in danger of stagnation



Features

- for supply lines with WPC, WPH, WNC or WNH
- complete unit ready for installation
- integrated solenoid valve
- integrated programmable electronic controls (selectable flushing intervals and durations)
- flow regulator 2.5 l/min, 6 l/min and 9 l/min included
- connection thread G 1/2B
- max. static pressure 8 bar

Options

Options	Art.-No.
power supply via battery	50 0100 00 01
power supply via plug-in power supply	50 0100 00 02
power supply via power pack for flush-mounted box	50 0100 00 03

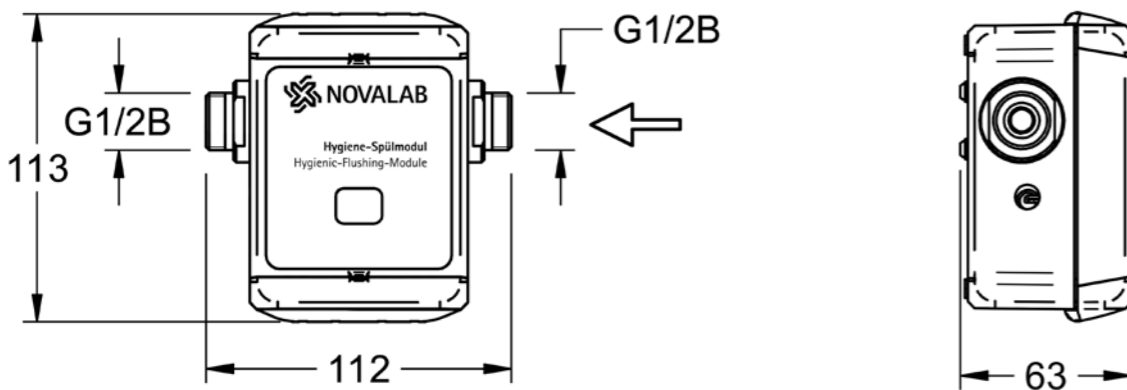

NOVALAB hygienic flushing module

for cyclical flushing of demi-water pipes
that are in danger of stagnation



Features

- for supply lines with WDC, WDH or WDI
- complete unit ready for installation
- integrated demineralized water suitable solenoid valve
- integrated programmable electronic controls (selectable flushing intervals and durations)
- flow regulator 2.5 l/min, 6 l/min and 9 l/min included
- connection thread G 1/2 B
- max. static pressure 8 bar

Options

Options	Art.-No.
power supply via battery	50 0100 00 04
power supply via plug-in power supply	50 0100 00 05
power supply via power pack for flush-mounted box	50 0100 00 06

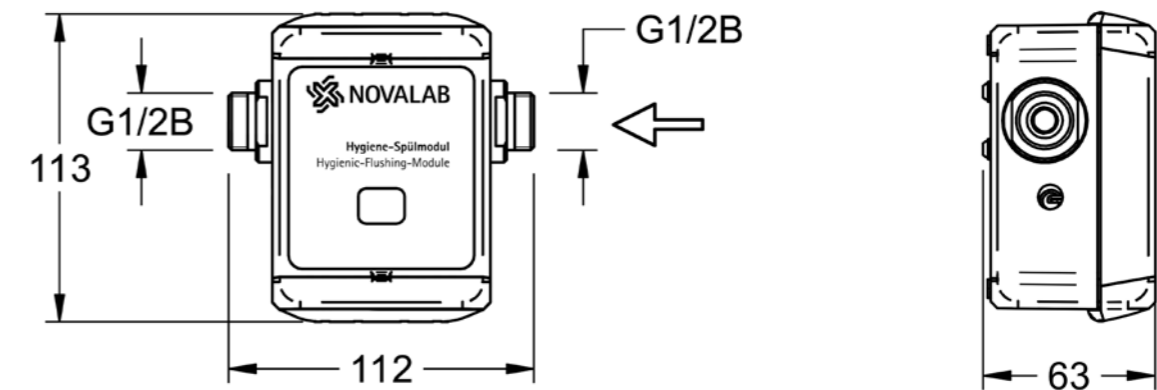

NOVALAB optoelectronic stand mixer DN 15

for connection to cold and warm water with integrated hygienic flushing for the cyclical flushing of water pipes that are in danger of stagnation

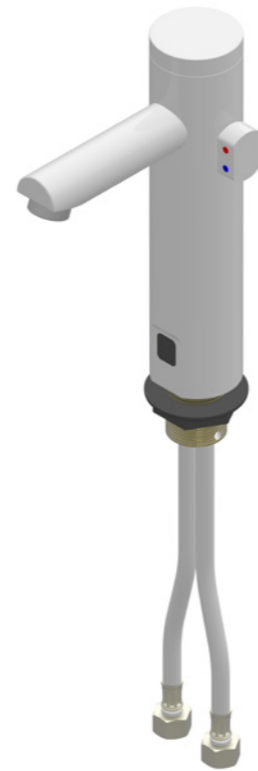

Features

- all-metal housing EPS coated in grey RAL 7035
- stable temperature selection lever with coloured temperature marking
- integrated solenoid valve cartridge and programmable electronic controls
- integrated hygienic flushing (can be switched off)
- G 3/8 connecting hoses with dirt traps and non-return valves
- safety shutdown at continuous reflection
- M33 x 2 fastening thread, 40 mm long
- incl. fastening set
- max. static pressure 8 bar

Options

Options	Art.-No.
power supply via battery	50 2000 00
power supply via plug-in power supply	50 2001 00
power supply via power pack for flush-mounted box	50 2002 00

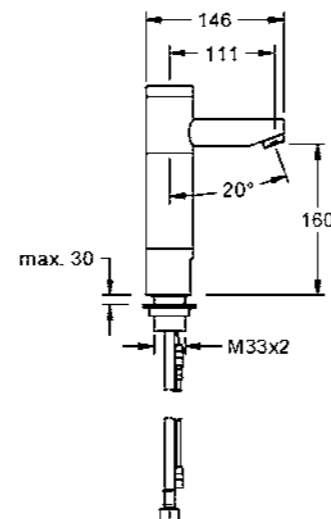
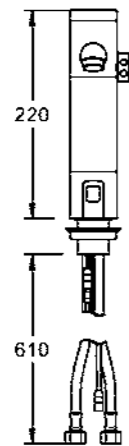

NOVALAB optoelectronic pillar tap DN 15

for connection to cold or premixed water with integrated hygienic flushing for cyclical flushing of water pipes that are in danger of stagnation

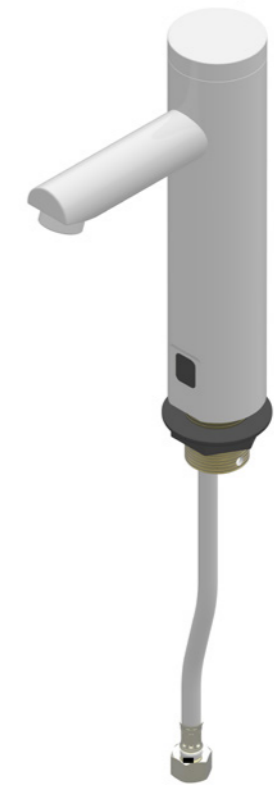

Features

- all-metal housing EPS coated in grey RAL 7035
- integrated solenoid valve cartridge and programmable electronic controls
- integrated hygienic flushing (can be switched off)
- connection hose G 3/8 with dirt trap
- safety shutdown with continuous reflection
- M33 x 2 fastening thread, 40 mm long
- incl. fastening set
- max. static pressure 8 bar

Options

Options	Art.-No.
power supply via battery	50 3000 00
power supply via plug-in power supply	50 3001 00

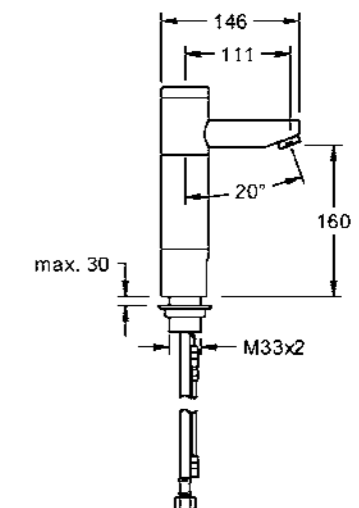
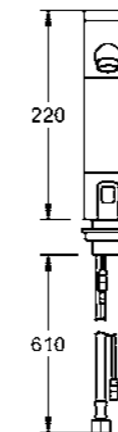

NOVALAB optoelectronic wall-mounted battery with thermostatic temperature control

for connection to cold and hot water (WPC / WPH) with integrated hygienic flushing for cyclical flushing of water pipes that are in danger of stagnation

Available from 08/2020

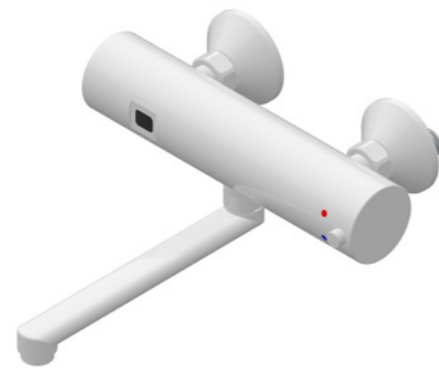

Features

- all-metal housing EPS coated in grey RAL 7035
- sensor for non-contact triggering with automatic switchover of near- / far-range detection
- integrated solenoid valve cartridge and programmable electronic controls
- integrated hygienic flushing (can be switched off)
- power supply via integrated exchangeable 6V lithium battery
- safety shutdown with continuous reflection
- swivel pipe shape spout (A = 200 mm)
- integrated backflow preventer and dirt trap
- max. static pressure 8 bar

Version with hose nozzle	Art.-No.
with S-connections, connection thread G 1/2B	50 4000 00
without S-connections, connection thread G 3/4 nut	50 4000 00 01
Version with aerator	Art.-No.
with S-connections, connection thread G 1/2B	50 4001 00
without S-connections, connection thread G 3/4 nut	50 4001 00 01

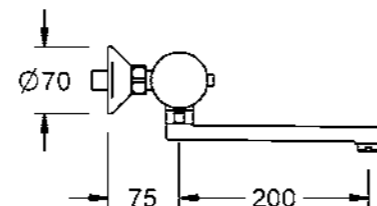
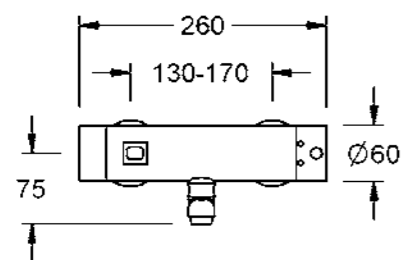

NOVALAB single-hole laboratory mixer with swivel spout

for connection to cold and warm water with hygienic flushing device for cyclical flushing of water pipes that are in danger of stagnation



Features

- coloured operating handles according to DIN EN 13792
- all-metal housing EPS coated in grey RAL 7035
- hygienic flushing device with integrated solenoid valve cartridge for automatic flushing of cold and hot water pipes via the end-fitting
- programmable electronic controls (selectable flushing intervals and durations)
- G 3/8 connecting hoses with dirt traps and non-return valves
- M33 x 2 fastening thread, 40 mm long
- incl. fastening set
- max. static pressure 8 bar

Version with hose nozzle , power supply via battery	Art.-No.
headwork with rubber seal	70 0390 35 37
headwork with ceramic discs, 180°	70 0390 35 37 02
Version with hose nozzle , power supply via plug-in power supply	Art.-No.
headwork with rubber seal	70 0391 35 37
headwork with ceramic discs, 180°	70 0391 35 37 02
Version with aerator , power supply via battery	Art.-No.
headwork with rubber seal	70 0392 35 37
headwork with ceramic discs, 180°	70 0392 35 37 02
Version with aerator , power supply via plug-in power supply	Art.-No.
headwork with rubber seal	70 0393 35 37
headwork with ceramic discs, 180°	70 0393 35 37 02

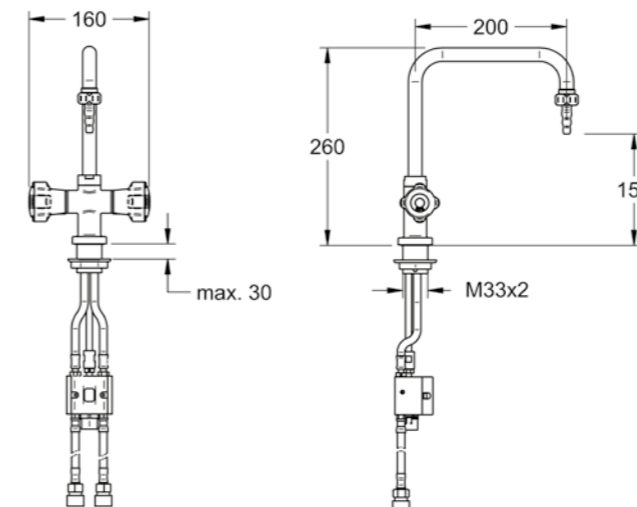

**NOVALAB laboratory
single-lever mixer DN 15 with
hygienic flushing device**

for cyclical flushing of water pipes that are in danger of stagnation, for connection to cold and hot water, with ceramic mixing cartridge, hot water limiter and swivel spout
(A = 200 mm)

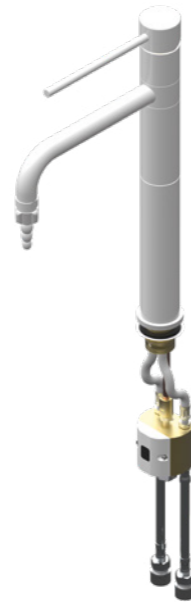

Features

- all-metal housing EPS coated in grey RAL 7035
- hygienic flushing device with integrated solenoid valve cartridge for automatic flushing of the cold and hot water pipes via the end-fitting
- programmable electronic controls (selectable flushing intervals and durations)
- long operating lever
- G 3/8 connecting hoses with dirt traps and non-return valves
- M32 x 1 fastening thread, 35 mm long
- incl. fastening set
- max. static pressure 8 bar

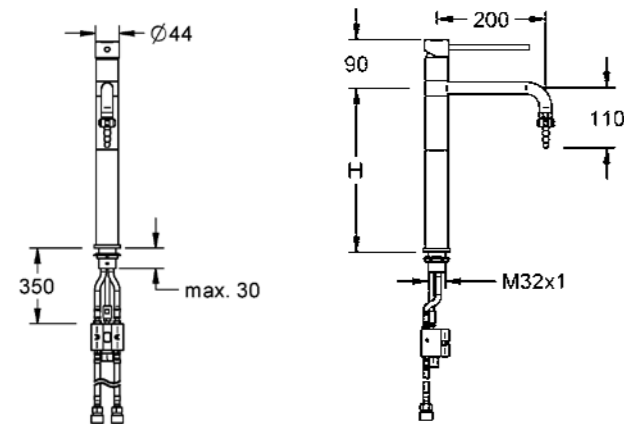

**Version height H = 200 mm,
power supply with battery Art.-No.**

with hose nozzle	70 2134 15 37
with aerator	70 2135 15 37

**Version height H = 300 mm,
power supply with battery Art.-No.**

with hose nozzle	70 3134 15 37
with aerator	70 3135 15 37

**Version height H = 200 mm,
power supply via plug-in power supply Art.-No.**

with hose nozzle	70 2136 15 37
with aerator	70 2137 15 37

**Version height H = 300 mm,
power supply via plug-in power supply Art.-No.**

with hose nozzle	70 3136 15 37
with aerator	70 3137 15 37

**NOVALAB optoelectronic
wall valve with elbow 90°**

pre-assembled on a stainless steel cover plate for connection to cold or pre-mixed water (WPC) with integrated hygienic flushing for the cyclical flushing of water pipes that are in danger of stagnation

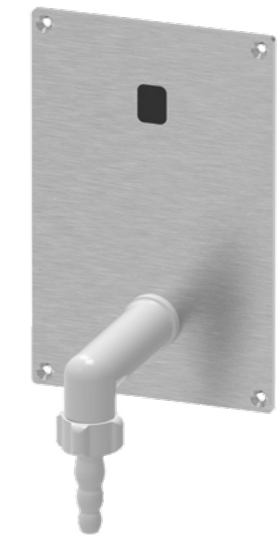

Features

- completely ready-to-install wall valve pre-assembled on stainless steel plate (optional EPS-coated grey RAL 7035)
- elbow 90° EPS coated grey RAL 7035 with hose nozzle
- sensor for non-contact triggering with automatic switchover of near / far distance detection (on request time-controlled special functions)
- solenoid valve and programmable electronic controls
- integrated hygienic flushing (can be switched off)
- connection thread G 1/2B
- max. static pressure 8 bar

Version projection A = 75 mm Art.-No.

power supply via battery	50 5000 00 01
power supply via plug-in power supply	50 5000 00 02

Version projection A = 100 mm Art.-No.

power supply via battery	50 5001 00 01
power supply via plug-in power supply	50 5001 00 02

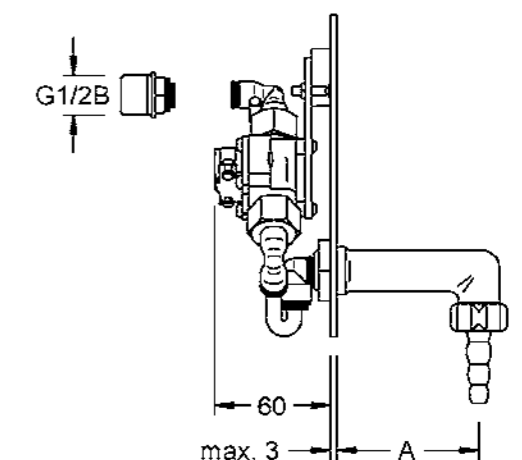
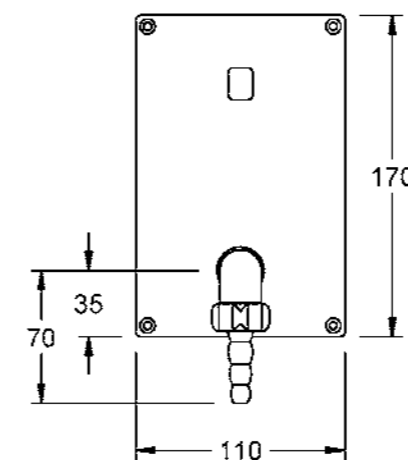

NOVALAB optoelectronic wall valve with elbow 90°

pre-assembled on a stainless steel cover plate for connection to demineralized water (WDC) with integrated hygienic flushing for cyclical flushing of demineralised water lines that are in danger of stagnation



Features

- completely ready-to-install wall valve pre-assembled on a stainless steel plate (optional EPS coated grey RAL 7035)
- 90° elbow made of high-performance plastic (PVDF) grey RAL 7035 with hose nozzle
- sensor for non-contact triggering with automatic switchover of near / far distance detection (on request time-controlled special functions)
- demi water suitable solenoid valve and programmable electronic controls
- integrated hygienic flushing (can be switched off)
- connection thread G 1/2B
- max. static pressure 8 bar

Version projection A = 75 mm	Art.-No.
power supply via battery	50 5000 00 04

power supply via plug-in power supply	50 5000 00 05
---------------------------------------	---------------

Version projection A = 100 mm	Art.-No.
power supply via battery	50 5001 00 04

power supply via plug-in power supply	50 5001 00 05
---------------------------------------	---------------

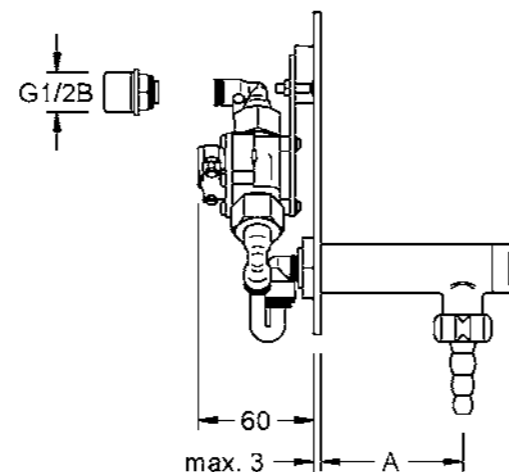
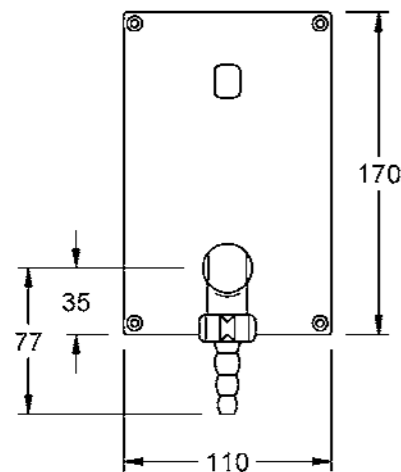

NOVALAB optoelectronic wall mixer with elbow 90°

pre-assembled on stainless steel cover plate for connection to cold and warm water (WPC / WPH) with mixing device and integrated hygienic flushing for the cyclical flushing of water pipes that are in danger of stagnation



Features

- completely ready-to-install wall mixer pre-assembled on stainless steel plate (optional EPS-coated grey RAL 7035)
- elbow 90° EPS coated grey RAL 7035 with hose screw connection
- sensor for non-contact triggering with automatic switchover of near- / far-range detection
- integrated solenoid valve cartridge and programmable electronic controls
- integrated hygienic flushing (can be switched off)
- G 3/8 connecting hoses with dirt traps and non-return valves
- max. static pressure 8 bar

Version projection A = 75 mm	Art.-No.
power supply via battery	50 6000 00 01

power supply via plug-in power supply	50 6000 00 02
---------------------------------------	---------------

Version projection A = 100 mm	Art.-No.
power supply via battery	50 6001 00 01

power supply via plug-in power supply	50 6001 00 02
---------------------------------------	---------------

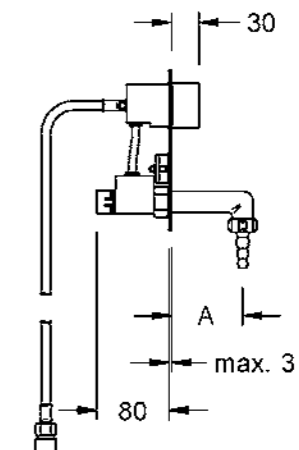
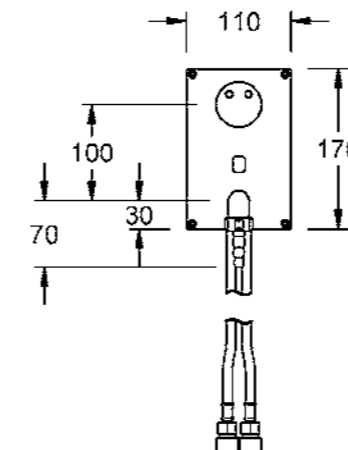

NOVALAB single-lever laboratory mixer DN 15

with ceramic mixing cartridge and hot water limitation, swivel spout (A = 200 mm) for connection to cold and warm water



- Features**
- all-metal housing EPS coated in grey RAL 7035
 - long operating lever
 - connection hoses G 3/8
 - M32 x 1 fastening thread, 35 mm long
 - incl. fastening set
 - max. static pressure 8 bar

Version height H = 200 mm	Art.-No.
with hose nozzle	70 2130 15 37
with aerator	70 2131 15 37
Version height H = 300 mm	Art.-No.
with hose nozzle	70 3130 15 37
with aerator	70 3131 15 37

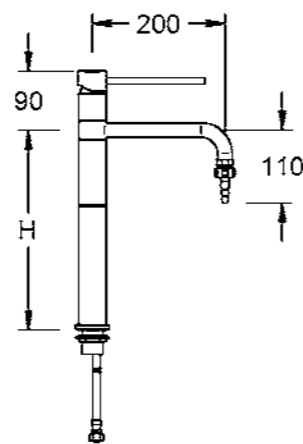
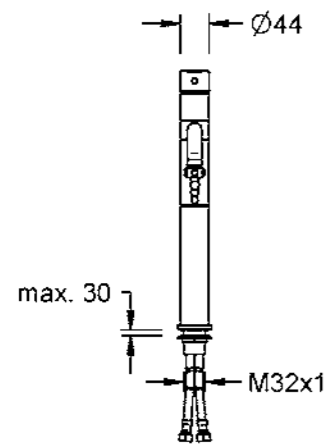

NOVALAB low pressure single-lever laboratory mixer DN 15

with ceramic mixing cartridge and hot water limitation, swivel spout (A = 200 mm) with jet regulator for under table mounted low pressure boiler



- Features**
- all-metal housing EPS coated in grey RAL 7035
 - long operating lever
 - connection hoses G 3/8
 - M32 x 1 fastening thread, 35 mm long
 - incl. fastening set
 - max. static pressure 8 bar

Version height H = 200 mm	Art.-No.
with jet regulator	70 2138 15 37
Version height H = 300 mm	Art.-No.
with jet regulator	70 3138 15 37

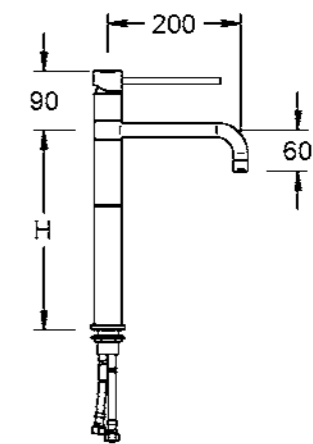
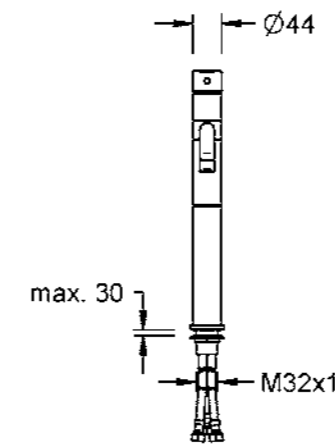

NOVALAB laboratory single lever mixer DN 15 with separate hand shower

with ceramic mixing cartridge and hot water limitation, swivel spout (A = 200 mm) for connection to cold and warm water (WPC / WPH)



Features

- all-metal end-fitting case EPS coated grey RAL 7035
- long operating lever
- plastic hand shower with table lead-through, connection hose 1.5 m
- automatic diverter when operating the hand shower
- connection hoses G 3/8
- M32 x 1 fastening thread, 35 mm long
- incl. fastening set
- max. static pressure 8 bar

Version height H = 200 mm Art.-No.

with hose nozzle	70 2132 15 37
with aerator	70 2133 15 37

Version height H = 300 mm Art.-No.

with hose nozzle	70 3132 15 37
with aerator	70 3133 15 37

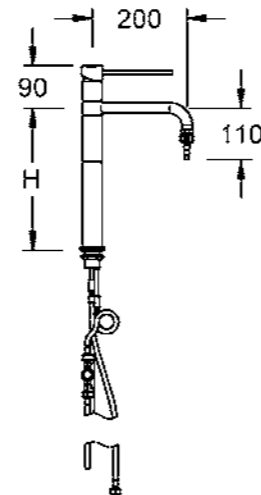
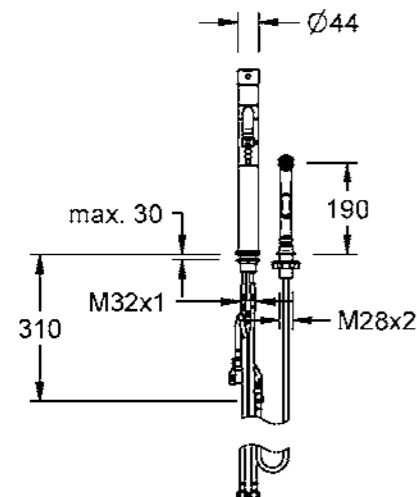

NOVALAB laboratory self-closing angle valve for water (WDC)

for connection to demineralized water

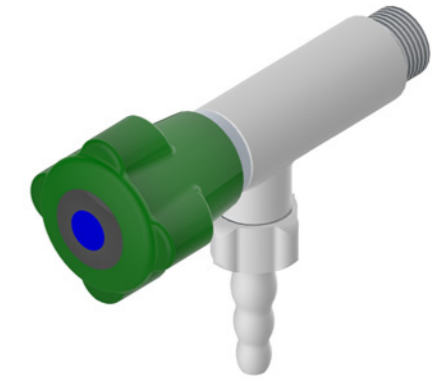

Features

- end-fitting case made of high-performance plastic (PVDF) grey RAL 7035
- coloured operating handle according to DIN EN 13792
- triggered by pressing the handle, quick stop at the end of the operation
- hose nozzle (diameter 10/13 mm) and jet regulator according to DIN 12898
- connection thread G 1/2B, 12 mm long
- max. static pressure 8 bar
- max. operating temperature 95° C

Options Art.-No.

projection A = 50 mm	70 0170 20 47 27
projection A = 75 mm	70 0171 20 47 27
projection A = 100 mm	70 0172 20 47 27

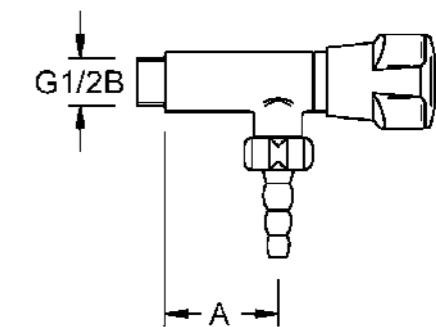
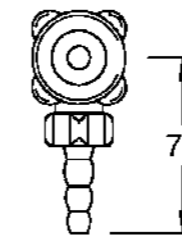

Antibacterial Handles

The Challenge

The surfaces of manually operated handles, switches as also devices and fittings are common sites for contamination through contact with microorganisms and their possible propagation.

These local micro-florae consisting of bacteria, fungi and viruses induced by such hand contact can be the source of specific harmful species (pathogenic) being dangerous to human health (faecal germs, pseudomonads etc.). Operating personnel and users of such manual switches and regulating devices may pick up such germs and transmit them to other surfaces.

The risk of transmission and dissemination of microbial pathogenic organisms is the result and presents a serious hygienic loophole, especially for laboratories and research facilities. NOVALAB has developed a new type of handle in response to this concern. The body material of this innovative handle features a microbicidal (antimicrobial) effect.

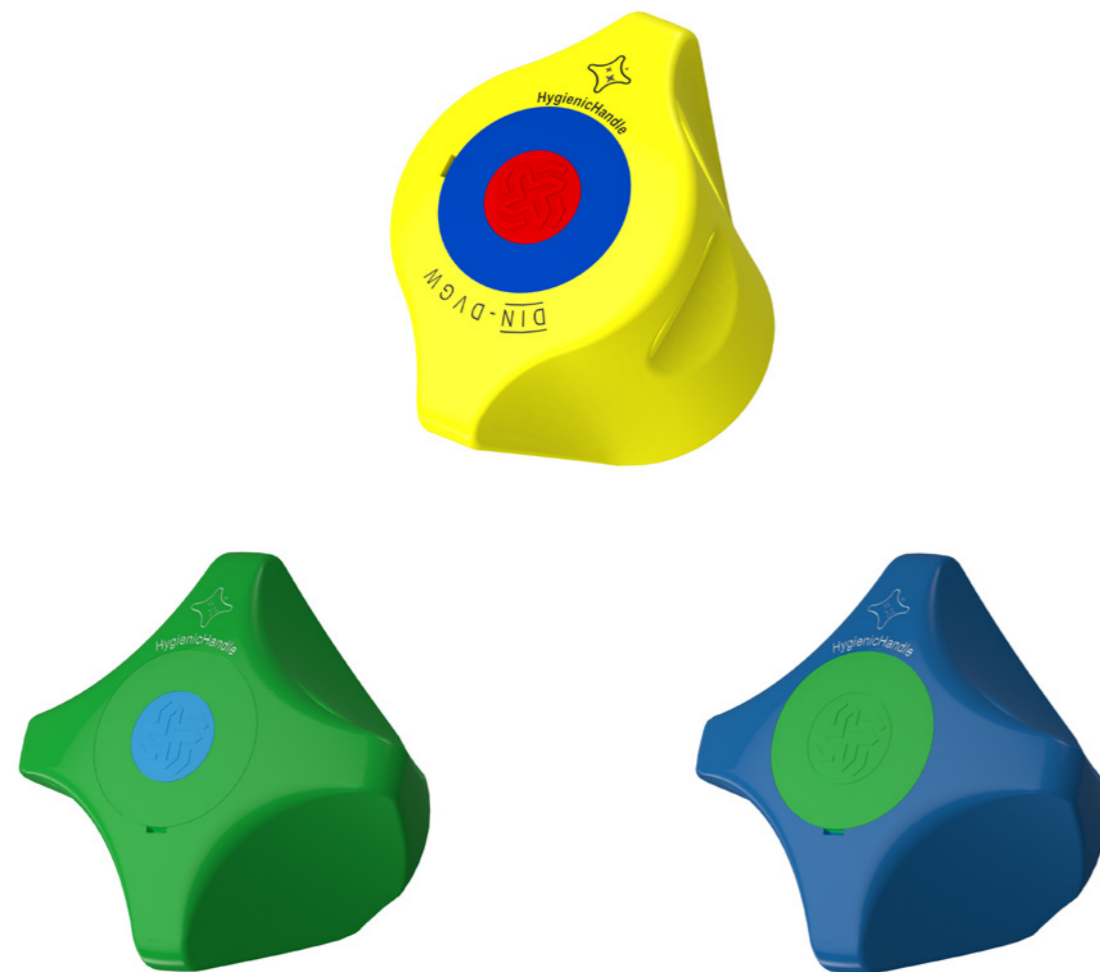

Process and Principle of Action

Special acids salts (metals from the eighth main group of the PSE) in micro-crystalline dispersion have been incorporated into the body material of the handle creating hotspots of high microbicidal effect on the surface (contact area). The applied micro-organisms which, through contact, can be found on the surface of the handle are inhibited (unable to reproduce) or killed on making contact with these hotspots. Transmission and dissemination of pathogens are therefore prevented at the highest level of safety.

Material Properties

The microbicidal dopants are not only on the surface of the handle but also incorporated as a material component. This provides the contact surface with a permanently active, abrasion-resistant, bio-effective concentration with properties including:

- ✓ temperature and light resistance
- ✓ chemical stability (air and air-components, cleaning substances and care, etc.)
- ✓ non-elutable as an agent
- ✓ inert to colour and material

Microbicidal Effectivity

The wide, nonspecific, antimicrobial efficiency of this procedure has already gone through numerous tests and proven itself many times over in various coating materials and material finishes.

The results of the active-time correlated germ reduction (CFU) as shown in chart 1 proves the microbicidal effect of this version developed by NOVALAB

This biocidal effect has been confirmed for the version developed by NOVALAB GmbH as a material immanent part of end-fitting handles.

Active-time correlated germ reduction [CFU] on model substrate (round sample plates) polyamide
 — with NOVALAB doping and — undoped polyamide

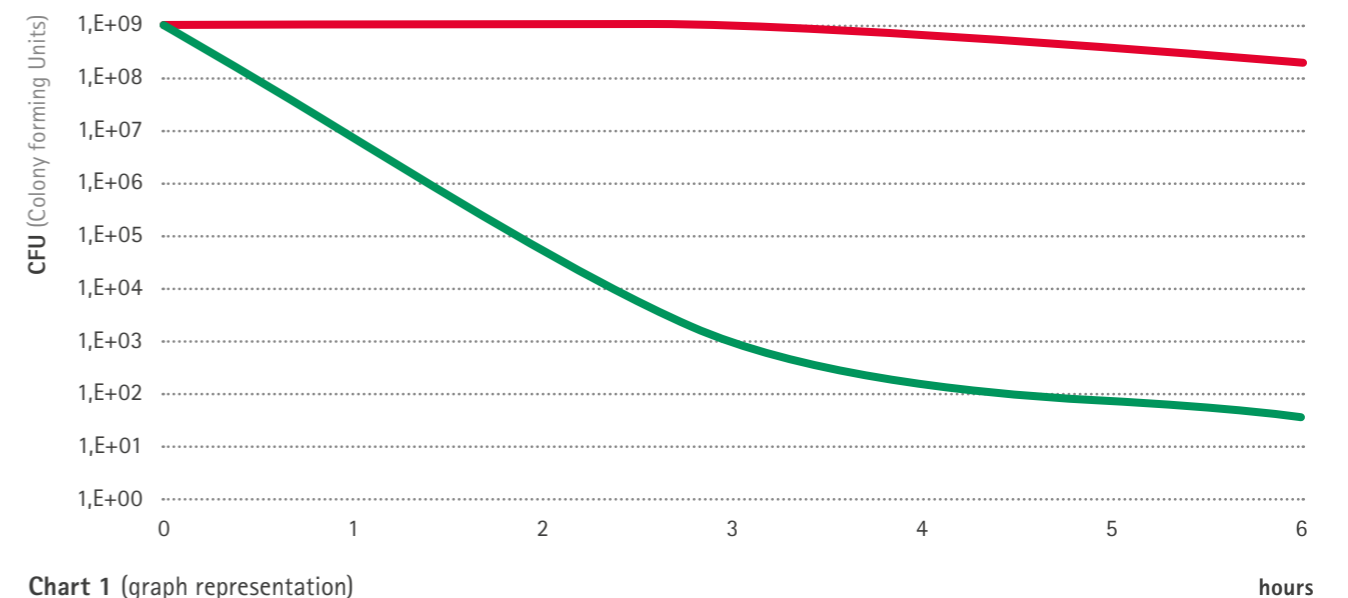

Chart 1 (graph representation)

Eye Showers

NOVALAB eye shower for table mounting with stainless steel braided pressure hose and table feedthrough; with DVGW type examination certificate

for connection to the water supply



Features

- robust plastic casing made of polyamide grey RAL 7035
- connection thread of the hand shower made of metal G 1/2B with integrated flow regulator, backflow preventer and dirt trap
- smooth, easy-to-clean surfaces
- for stationary or flexible use
- not automatically self-closing
- rinses both eyes at the same time with sufficient water
- constant flow rate of 12 l/min from 1.8 bar flow pressure
- constant jet height with a soft water jet regardless of the flow pressure
- triggered by pressing the wing button, water stopped by pulling the button
- interchangeable jet formers with special tool
- dust cap green RAL 6032 including pictogram printing eye shower
- table feed-through made for fixed insertion of the hand shower and fastening set
- technical product information including safety sign "eye shower" as adhesive film
- compliant with DIN EN 15154-2, DGUV Information 213-850, UBA Metals, UBA KTW-BWGL, UBA Elastomers, DVGW W 270
- max. static pressure 8 bar
- connection thread on hose G 3/8

Art.-No.

70 1340 15

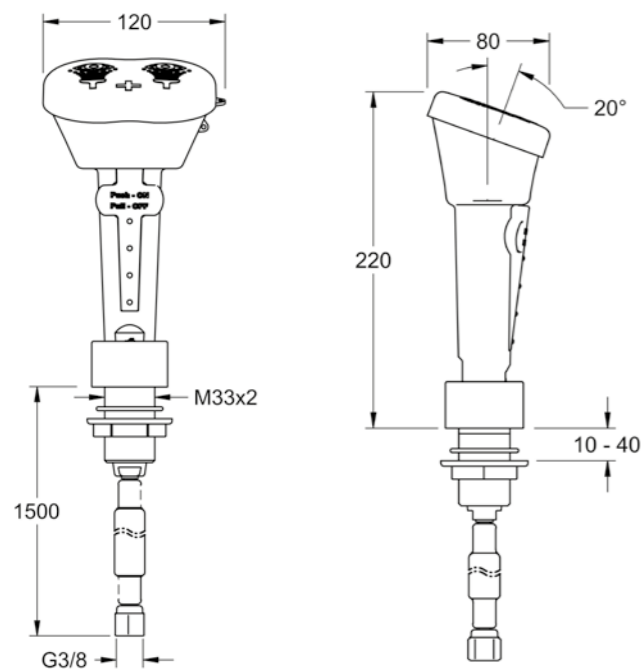

NOVALAB eye shower for wall mounting on laboratory furniture with stainless steel braided pressure hose and wall bracket with wall duct; with DVGW type examination certificate

for connection to the water supply



Features

- robust plastic casing made of polyamide grey RAL 7035
- connection thread of the hand shower made of metal G 1/2B with integrated flow regulator, backflow preventer and dirt trap
- smooth, easy-to-clean surfaces
- for stationary or flexible use
- not automatically self-closing
- rinses both eyes at the same time with sufficient water
- constant flow rate of 12 l/min from 1.8 bar flow pressure
- constant jet height with a soft water jet regardless of the flow pressure
- triggered by pressing the wing button, water stopped by pulling the button
- interchangeable jet formers with special tool
- dust cap green RAL 6032 including pictogram printing eye shower
- wall duct made for fixed insertion of the hand shower and fastening set
- technical product information including safety sign "eye shower" as adhesive film
- compliant with DIN EN 15154-2, DGUV Information 213-850, UBA Metals, UBA KTW-BWGL, UBA Elastomers, DVGW W 270
- max. static pressure 8 bar
- connection thread on hose G 3/8

Art.-No.

70 1342 15

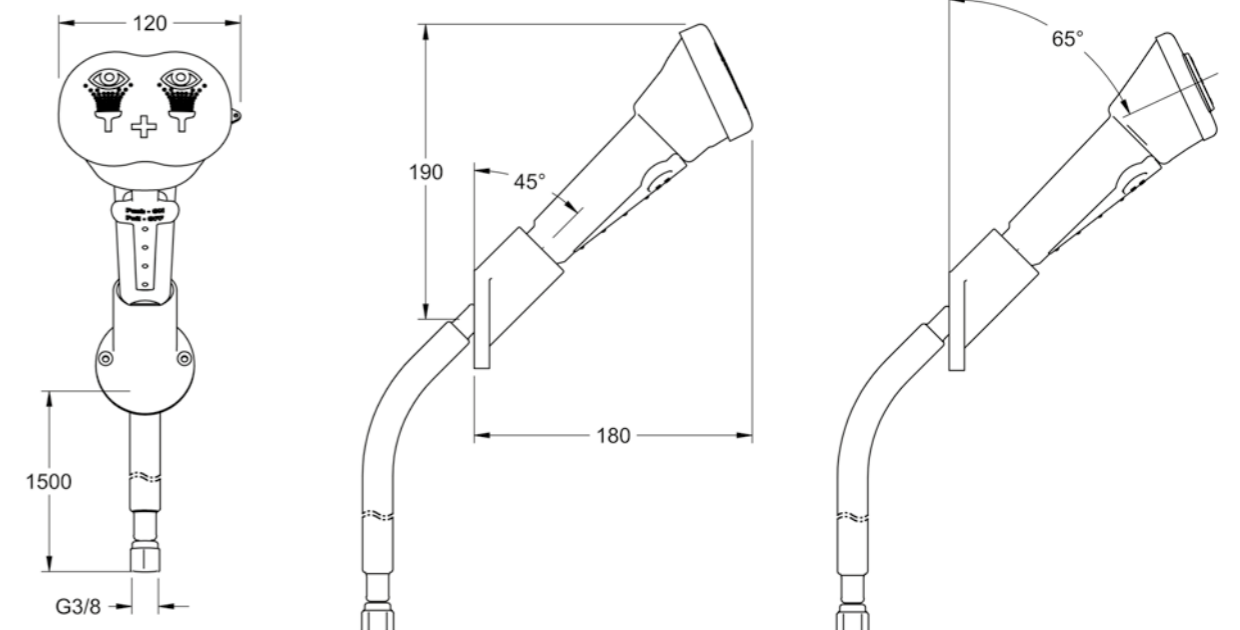

NOVALAB eye shower for wall mounting with stainless steel braided pressure hose; with DVGW type examination certificate

for connection to the water supply



Features

- robust plastic casing made of polyamide grey RAL 7035
- connection thread of the hand shower made of metal G 1/2B with integrated flow regulator, backflow preventer and dirt trap
- smooth, easy-to-clean surfaces
- for stationary or flexible use
- not automatically self-closing
- rinses both eyes at the same time with sufficient water
- constant flow rate of 12 l/min from 1.8 bar flow pressure
- constant jet height with a soft water jet regardless of the flow pressure
- triggered by pressing the wing button, water stopped by pulling the button
- interchangeable jet formers with special tool
- dust cap green RAL 6032 including pictogram printing eye shower
- wall bracket made for fixed insertion of the hand shower and fastening set
- technical product information including safety sign "eye shower" as adhesive film
- compliant with DIN EN 15154-2, DGUV Information 213-850, UBA Metals, UBAKTW-BWGL, UBA Elastomers, DVGW W 270
- max. static pressure 8 bar
- connection thread on hose G 3/8

Art.-Nr.

70 1344 15

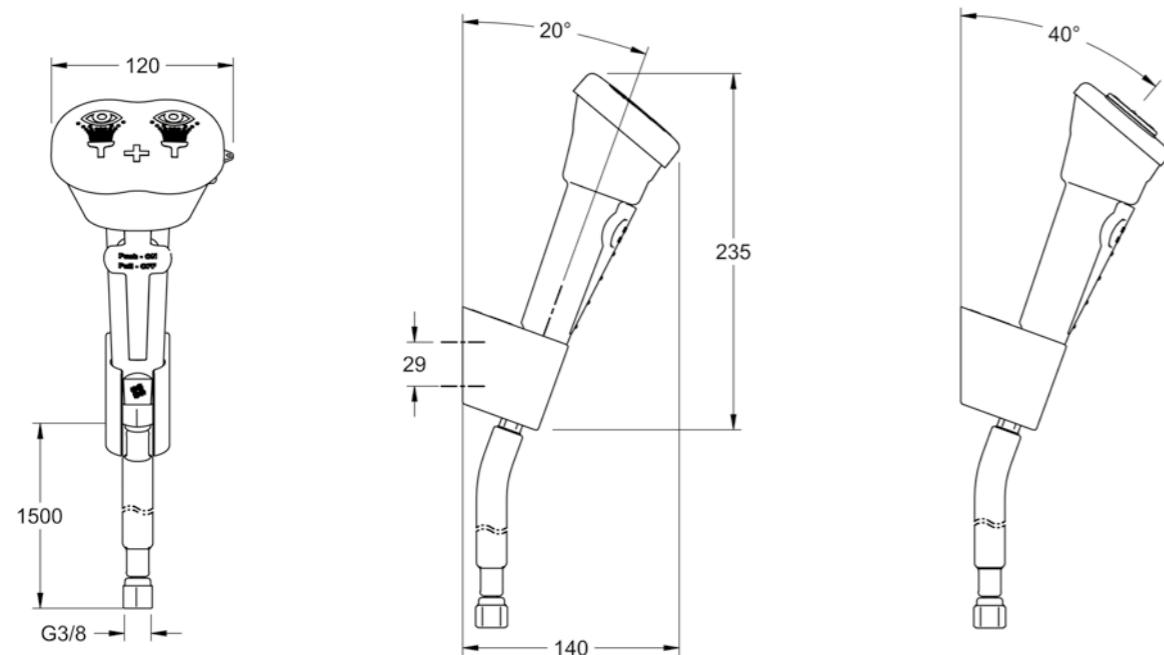

NOVALAB eye shower for mounting on walls with spiral pressure hose

for connection to the water supply



Features

- robust plastic casing made of polyamide grey RAL 7035
- connection thread of the hand shower made of metal G 1/2B with integrated flow regulator, backflow preventer and dirt trap
- smooth, easy-to-clean surfaces
- for stationary or flexible use
- not automatically self-closing
- rinses both eyes at the same time with sufficient water
- constant flow rate of 12 l / min from 1.8 bar flow pressure
- constant jet height with a soft water jet regardless of the flow pressure
- triggered by pressing the wing button, water stopped by pulling the button
- interchangeable jet formers with special tool
- dust cap green RAL 6032 including pictogram printing eye shower
- wall bracket made for fixed insertion of the hand shower and fastening set
- technical product information including safety sign "eye shower" as adhesive film
- compliant with DIN EN 15154-2, DGUV Information 213-850
- max. static pressure 8 bar
- connection thread on hose G 3/8

Art.-Nr.

70 1346 15

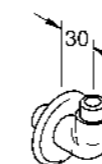
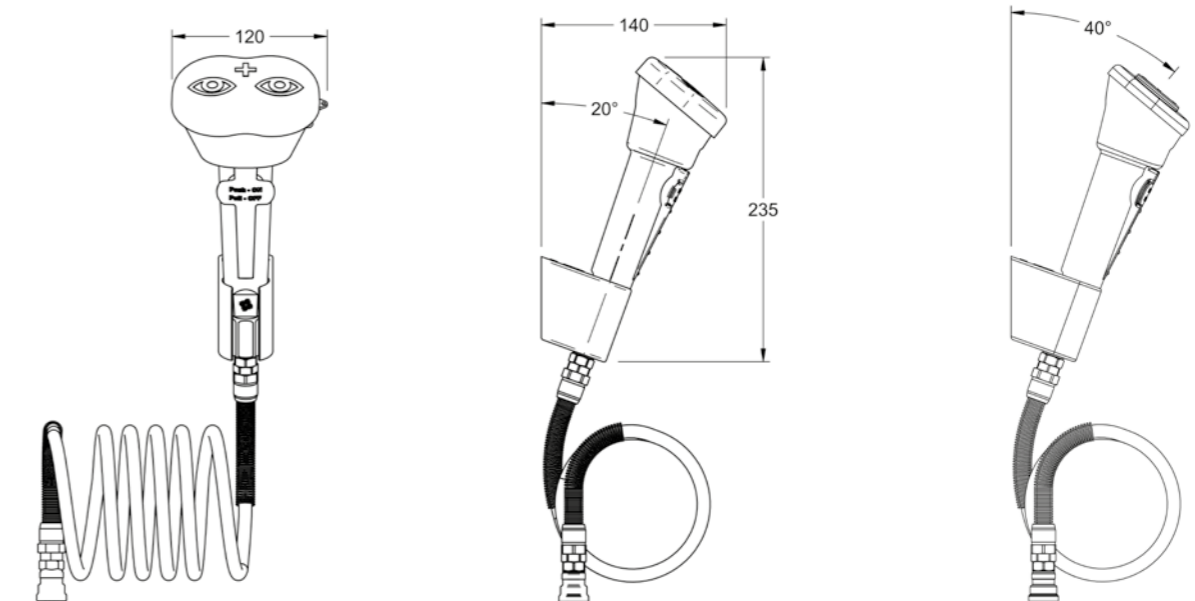

ACCESSORY: NovaLab connector knee with wall rosette for hand-eye-wash fountain

- brass EPS-coated green. RAL 6032
- Connection: Male thread G 3/8B

Art.-Nr. 71 1060 15

NOVALAB
Labor- und Gartenarmaturen GmbH
Brunsbütteler Damm 440
13591 Berlin, Germany

Phone: +49 30 364033620
E-Mail: info@novalab-gmbh.de
www.novalab-gmbh.de





www.novalab-gmbh.de

